

# INSTRUCTION SHEET

## Safety Laser Scanner SE2L-H05LPC

Confirm that the delivered product is what you have ordered. Read this quick reference guide to make sure of correct operation. Make sure that the quick reference guide is kept by the end user.

SE2L-H05LPC is used with an Optional Connector cable (SE9Z-HS2-C\*\*).  
(\*\*\*: 002=2m, 005=5m, 010=10m, 020=20m)

### Notice for Safety

Special markings and symbols are used in this document to alert the reader especially to safety-related issues. Follow strictly the instructions marked by these special markings and symbols to ensure safety during the operation.

Mark	Meaning
	Procedures that could lead to dangerous situation, critical injury or death if not carried out properly.

Refer SE2L user's manual for details.  
Read section 12 "Instruction for using SE2L for the first time afterpurchase" when using the device for the first time.

## 1 Safety precautions

### DANGER

- Please read the following guidelines for correct use of the SE2L. Proper handling and usage ensure the SE2L to operate accordingly.

#### (1) General

### DANGER

- SE2L is an AOPDDR that detects obstacles within the configured protection zone by detecting diffused optical radiation. Optical radiations are generated and emitted into the configured protection zone. The optical radiations are then rotated by a rotating motor covering the protection zone. The optical radiations are diffused and reflected back towards the receiving unit of the SE2L.
- SE2L is designed to protect human beings or systems by monitoring the hazardous area. It is not designed for the protection from high speed objects or the electro magnetic radiation.
- Pre-operation tests must be performed in order to verify the functionality and the performance of the SE2L.
- Do not modify or disassemble SE2L. Such modifications will affect the detection capability leading to injuries or death.
- Do not modify or disassemble SE2L to maintain its housing rating. Such modifications will void the warranty.
- Operator is referred to a person who is responsible and qualified to operate the SE2L. Operator should have attended appropriate safety-related training and could operate the SE2L correctly.
- A person-in-charge must be assigned and have trained the operator about the correct use of SE2L.
- The person-in-charge is responsible to ensure the proper working environment for SE2L.
- The person-in-charge is responsible for the compliance with the local safety requirements, standards, rules and regulations, laws of respective nations, states or districts when the SE2L is used in a safety-related system.
- SE2L has been manufactured and shipped under the strict quality control. If you find any defect in the product contact the nearest distributor or sales representative.
- IDEC cannot be held responsible for the damages or failure due to misuse of the product by customers or third parties. IDEC cannot take responsibilities for any loss from the misuse except for the responsibilities governed by law.
- User should prepare test pieces for detection capability verification. The test piece should emulate the smallest object that is intended to be detected during the operation.
- Maximum level of homogeneous pollution for SE2L is 30%. Warning signal will be displayed if the pollution exceeded the stated limit. However, operator should always keep the optical window in clean condition.
- Before resetting the interlock of the SE2L, operator must ensure the surrounding is safe especially in the protection zone.
- During decommission of the SE2L, protective measures must be taken to ensure safety on the protection zone. Protective materials such as guards or light curtain should be used to prevent any passage into the hazardous area.
- SE2L including its accessories are subject to change without prior notice for the improvement.
- SE2L should be disposed as industrial waste or in accordance with the local disposal directives.
- Do not drop the product. Otherwise, the product may be damaged, lead to failure and the performance will be degraded. Injury may also be caused.

#### (2) Operating environment

### DANGER

- Make sure that SE2L's operating environment is within the stated specification (temperature, humidity, ambient light, etc.). Using SE2L in the out-of-spec environment may cause malfunction or decrease the detection capacity.
- Do not use or mount SE2L near devices that could generate strong electromagnetic waves as it could affect the operation of SE2L.
- Do not use or mount SE2L in dusty, smoky, or misty environments, or where corrosive substances are present. Operating under such environments may decrease the detection capacity of SE2L.
- This product is for indoor use only.

#### (3) Installation

### DANGER

- Install the SE2L on a firm surface or structures to avoid displacement of the sensor.
- The SE2L should be firmly mounted using screws. Shock and vibration should not loosen the mounting. SE2L will not operate properly if the protection zone is different from the intended area due to the displacement. Recommended torque for screws is 3 N·m.
- Safety distance must be determined before installing SE2L. User must ensure the functionality of the SE2L after installation by placing a test piece in all the protection zone.
- During the installation of the SE2L, protective materials such as guards or light curtain should be used to prevent any passage into the hazardous area.

- Reset switch used for interlock, muting and override function should be mounted at a location away from the protection zone. Also the whole protection zone must be visible from the switch location.
- Mutual interference could occur when identical SE2Ls are mounted at the same detection plane.
- SE2L should be mounted at a location which has sufficient space for maintenance.
- Do not add any protective materials such as glass, transparent cover etc in front of the optical window. This would lead to loss of detection capability of the SE2L.
- Minimum detectable width varies with the distance.

#### (4) Wiring

### DANGER

- Switch OFF all the power supply during wiring.
- If the source of the power supply is taken from a converter, please ensure the power supply fulfills the following requirements:
  - A rated output voltage of 24VDC ±10% (SELV circuit, Overvoltage Category II)
  - Reinforced insulation or double insulation for the primary and secondary circuit
  - Holding time of the output should be above 20ms
  - The power supply must comply with the requirements of electrical safety and electromagnetic compatibility (EMC) regulations of the respective country, states and district.
- All the input/output signal cables should be installed away from machines power lines and high-voltage cables.
- Use OSSD of the SE2L to control safety-related machine/system. Do not use Warning signals to control safety-related machine as these are non-safety signals.
- Both the OSSD1 and OSSD2 outputs should be connected to the safety-related machines or control system. If OSSD3 and OSSD4 are used they must be connected in the same manner.
- Use shield cable for the connection between OSSD signals and safety-related machines or systems.

#### (5) Configuration

### DANGER

- Configuration of safety functions are password protected. Only authorized personnel or operator with password are allowed for configuration.
- SE2L will not operate without an initial configuration.
- Pre-operation test must be performed to verify the configurations before operating the SE2L.
- Increasing the response time of OSSD will increase the stability of SE2L. However, this will reduce the detection capability towards moving objects. User must perform risk assessment before using this function.
- Changes made during the configuration must be recorded. Operator can use the report generating function in the SE2L Project Designer.

#### (6) Test and maintenance

### DANGER

- User must perform the following tests and maintenance by referring to the checklists in this manual.
  - Pre-operation inspection
  - Operation inspection
  - Daily inspection
  - Periodical inspection
- The checklists in this document are provided as basic guidelines while performing the test and maintenance. User must perform additional inspection and maintenance tasks deemed necessary for the respective application.
- Stop the machine and stop using the SE2L if faults are detected during these tests.
- Clean the optical window when it gets contaminated. If the optical window is damaged it should be replaced by a new one.

## 2 Specification

Subject	Specification	
	SE2L-H05LPC	
	Protection Range	Max. 5.0m
	Warning Range	Max. 20.0m (Non-safety) *1
	Distance tolerance *2	+100mm
	Distance capability	From Black-Reflector Sheet (1.8%) to Retro-Reflector Sheet
Detection property	Detection angle	270°
	Minimum Detectable Width	ø30mm (Max. 1.8m) ø40mm (Max. 2.5m) ø50mm (Max. 3.0m) ø70mm / 150mm (Max. 5.0)
	Scan Frequency	30ms (Rotational Speed 2,000rpm)
	Scan area	Max. 32 patterns (128 when encoder input function is used)
	Response time	OFF (ON -> OFF) 60 to 2,010ms ON (OFF -> ON) 270 to 2,010ms
Optics	Element	Pulsed Laser Diode
	Wavelength	905nm
	Safety Class	Laser Class1 (IEC60825-1)
Type	Type 3 (IEC61496-1, IEC61496-3)	
Functional Safety	SIL 2 (Type B, HFT=1) (IEC61508)	
PFHd	7.8×10 <sup>-8</sup> (T1=20 year): When master slave function is not in use. 1.6×10 <sup>-7</sup> (T1=20 year): When master slave function is in use.	
Housing	Size	95.0H×80.0W×80.0D (mm)
	Weight	0.5kg
	Protection	IP65
	Case Material	Body: Aluminum Optical Window: Polycarbonate
	Cable	Waterproof connector: 0.3m
Power Supply	24VDC ±10%: when operation using converter power supply 24VDC -30/+20%: when operation using battery	
Supply current	Normal (Without load)	6W
	Max. (With load)	50W
Output types	OSSD1/2 (Safety - related)	Output type (High side SW) Output current (Max.: 500mA) *3 Leak current (Max.: 1mA) Cable (AWG 26) Load (L/R=25ms, C=1µF)
	OSSD3/4 (Safety - related) WARNING1/2 (Non - safety)	Output type (High side SW) Output current (Max.: 250mA) *3 Leak current (Max.: 1mA) Cable (AWG 28) Load (L/R=25ms, C=1µF)

Subject	Specification	
Output types	RES_REQ1 / RES_REQ2 MUT_OUT1 / MUT_OUT2 AUX_OUT1 / AUX_OUT2	Output type (PNP Transistor) Output current (Max.: 200mA) Leak current (Max.: 1mA) Cable (AWG 28)
Input Signal (Safety - related)	Area switching (5 inputs×2 channels) EDM1 / EDM2 MUTING1 / MUTING2 MUTING3 / MUTING4 OVERRIDE1 OVERRIDE2 RESET1 / RESET2 ENC1_A / ENC1_B ENC2_A / ENC2_B	Input Impedance 4.7kΩ Cable (AWG 28)
Interface	Configuration	USB2.0 (USB micro type-B connector)
		RS-485
Environmental resistance	Ethernet	Ethernet 100BASE-TX (Water proof connector)
	Temperature	-10 to +50°C (No freezing)
	Storage Temperature	-25 to +70°C (No freezing)
	Humidity	95% RH (No condensation)
	Storage Humidity	95% RH (No condensation)
	Surrounding Intensity *4	Less than 1,500lx
	Vibration	Frequency range: 10 to 55 Hz Sweep rate: 1 octave/min Amplitude: 0.35mm±0.05mm
	Bump	Acceleration: 98m/s <sup>2</sup> (10G) Pulse duration 16ms
	Outdoor Operation	Not permitted
	Altitude	Below 2,000m

\*1 Distance when reflectance of the object is 90% or above.

\*2 Additional distance of 200 mm is needed when the SE2L is working under high reflective background.

\*3 Total current supply of OSSD output and Warning output should be below 1.0A.

\*4 When the light sources located at ≥ 5° from the detection plane of SE2L.

## 3 Dimensions

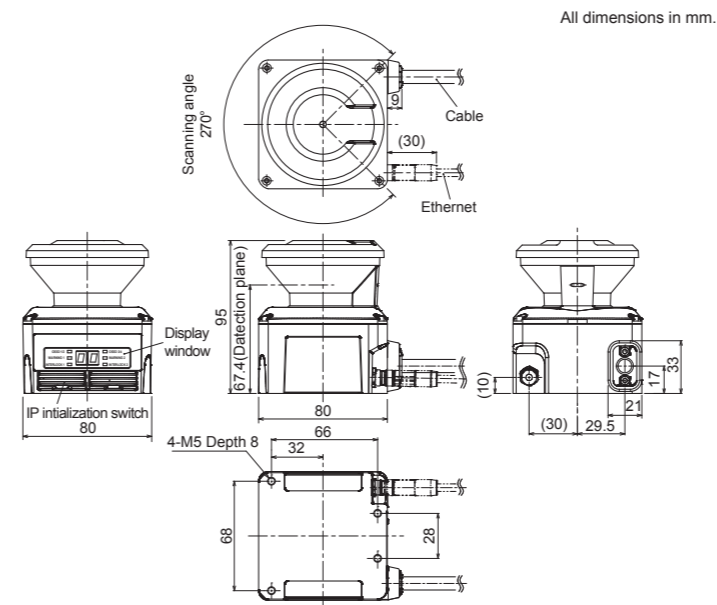

\* Refer SE2L user's manual for details.

## 4 SE2L components

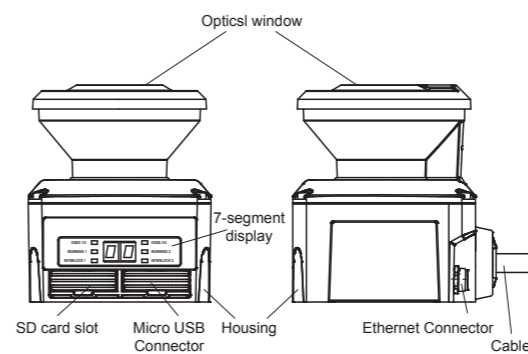

## 5 Functions

SE2L's function can be configured using the SLS Project Designer.

#### (1) Scanning area

Scanning area of SE2L consists of protection zone and warning zones. Maximum 32 sets of area can be configured. Further, two combinations for protection and warning zones can be selected for the operation.

- Protection zone, Warning zone 1 and Warning zone 2
  - 2 Protection zones (Dual Protection)
- In dual protection mode, two protection areas can be configured through two machines can be protected by one unit of SE2L. Protection and warning zones can be configured by using SLS Project Designer.

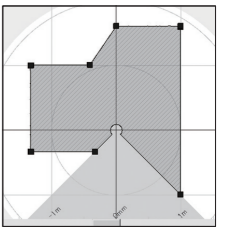

Fig-1. Protection zone configured using manual mode

- Protection zone  
Protection zone is safety-critical and directly connected to the OSSD signal. When an obstacle is detected in the protection zone, SE2L will switch the OSSD from ON-state to OFF-state (which should trigger a switch to stop a machine or AGV). For mobile applications, the OSSD signal can be used as the emergency stop signal. Figure 1 shows the examples of protection zone configured using manual mode and teaching mode respectively. User must configure these zones accordingly to ensure hazardous area is completely protected.

- Warning zone  
Warning zones are non-safety zones and are connected to Warning1 and Warning2 outputs. When the obstacle is detected in the warning zones, SE2L will switch the respective warning signal from ON-state to OFF-state. Warning signals can be used as an alert signal to avoid human beings or objects from approaching near the protection zone. For mobile applications, warning signals can be used for reducing the speed of automatic guided vehicle (AGV) to avoid collision.

#### (2) OSSD

OSSD is safety-related signal. When humans or objects are detected in the protection zone, the OSSD signal will switch to OFF state from ON-state. OSSD signal has the self-diagnostic function which tests the signal periodically. Signal is continuously switched to OFF-state when an error is detected during the diagnostic.

Output states of OSSD1 and OSSD2 signal are identical. Both signals should be connected to the safety related machines or control system to fulfill the required safety level. If OSSD3 and OSSD4 are used they must be connected in the same manner.

#### (3) Interlock function

Interlock is a function to prevent automatic restart of the OSSD signal switching from OFF-state to ON-state. OSSD1/2, RES\_REQ1 and RESET1 are for protection zone 1; OSSD3/4, RES\_REQ2 and RESET2 are for protection zone 2 when setting the sensor by SLS Project Designer. We use OSSD, RES\_REQ and RESET in the rest of this document as representative terms.

- Automatic restart  
SE2L will restart automatically when interlock function is disabled or the restart interlock function is set "auto" when interlock is enabled. When obstacle from the protection zone is removed, OSSD signals switch from OFF-state to ON-state automatically. However, if SE2L is in the lockout state due to error, OSSDs will remain in OFF-state even if the interlock function is disabled.

- Manual restart  
When interlock function is set to manual restart mode, even if the detected obstacles or system error is removed, OSSD signals will remain in OFF-state. An external reset input signal is required to release the interlock which allows the SE2L to switch to normal operation. RES\_REQ signal will be switched to ON state when obstacles disappear from protection zone. SE2L will resume normal operation only after confirming the reset signal (RESET). The duration of the reset signal should be more than 500ms. After RES\_REQ signal becomes ON and reset signal is confirmed, the OSSD signal will switch to ON-state after the lapse of the configured delay time. If OSSD's OFF-state is due to an internal fault, it will remain in OFF-state even when reset signal is provided. Reset delay is configurable in the range of 1s to 6s.

- Manual start  
Start interlock is a function which keeps the OSSD in OFF-state during the start-up until an external reset input is applied. Start interlock setting has only manual mode. The RES\_REQ signal switches to ON-state after the SE2L completes initial routines and ready to accept the RESET input. When RESET input is applied, OSSD will switch to ON state if no object is detected in the protection zone. The duration of the reset input should be more than 500ms. Delay can be configured in the range of 1s to 6s.

#### (4) External device monitoring (EDM) function

EDM is a function that monitors the state of the input signal from the controlled machine or automated guided vehicle (AGV). EDM is configured using the SLS project designer. When EDM function is enabled, any fault detected in EDM signal will switch the OSSD signal to OFF-state. Logic of EDM signal should be always inverse of the OSSD signal. EDM input signal ON/OFF delay is configurable to match the user's system. Please do not connect EDM input when this function is not needed.

#### (5) Muting function

Muting function temporarily suspends the safety function in the configured zone of SE2L when the specified conditions are fulfilled. In the muting state OSSD remains in the ON-state even when an object is detected in the configured muting zone. Two independent hard wired input signals are provided to start and end the muting function. Muting zone is configured using the SLS project designer. When muting inputs fulfill the muting start conditions, SE2L will suspend the safety function for the muting zone within 60ms.

- Muting start condition  
Muting function will start when the following conditions are fulfilled:
  - There are no objects in the protection zone and the OSSD is in ON-state.
  - The two independent hard wired muting input signals are switched to ON state in the predefined sequence within the pre-set time interval. However, the switching interval between two input signals should not be 0.
- Muting stop condition  
Muting function will stop when any one of the condition below is fulfilled:
  - One of the muting inputs switches to OFF-state.
  - When the muting state exceeds the predefined maximum muting time.
  - Objects are detected in the protection zone which is not covered by the muting zone.
  - Error is detected by the self-diagnostics function.
  - During muting state when the area is switched to another area.

- Muting override function  
Muting override is a function to recover SE2L when the OSSD is switched to OFF state due to muting related errors by temporarily suspending the safety function. Override function is active when the override input (OVERRIDE 1/2) and the reset input (RESET1/2) are switched in a sequence.

## (6) Reference monitoring function

Reference monitoring is a function to monitor the displacement of the SE2L or the structure used as reference boundary.

### • Access protection

An example of reference monitor function used for access protection is shown in figure 2. Reference segments should be configured on each surface for displacement detection. Reference segments should be configured such that displacement can be easily detected. The OSSD will switch to OFF-state when access penetration is detected, and also if the distance between SE2L and the reference structure changes. This function is compulsory for vertical applications.

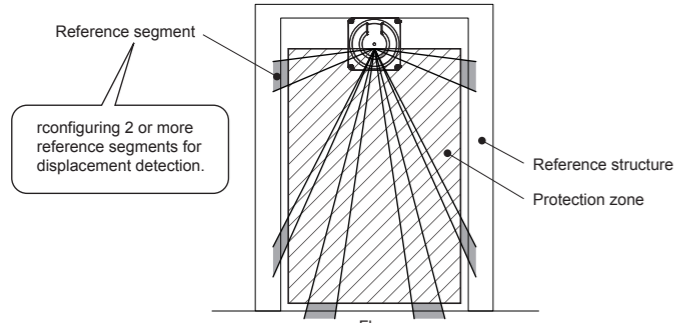

Fig-2. Front view of the access detection using reference monitor function

\* This function can be also used in area protection applications. Refer to User's Manual for the detail.

## (7) Area sequence function

Area sequence is a function to monitor sequences of area switching.

When this function is activated, OSSD signal will switch to OFF-state if the switching pattern is other than the configured sequence. This function prevents the machine to operate with random protection zone.

From each area, switching selection to maximum 31 other areas is possible when configuring the area sequence. And, it is necessary to specify 1 or more areas to avoid error.

### <Area switching sequence>

When area sequence is disabled, SE2L can switch from an area to any other areas (Figure 3) whereas it can only switch to specified areas if area sequence is enabled. (Figure 4).

Area sequence function is recommended for control systems where switching area sequences can be configured.

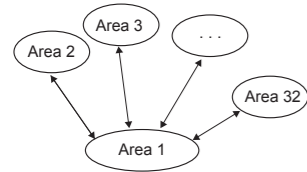

Fig-3. Operation without area sequence

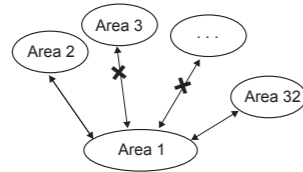

Fig-4. Operation with area sequence

## (8) Response time

Response times of OSSD signal, OFF response time and ON response time are configurable individually for each area using the SE2L project designer. Response time of the Warning 1 and Warning 2 will be same as the OSSD response time. Table 1 shows the possible configurable values. In the dual protection mode, it is possible to set a separate response time for each protection area.

When longer response time is configured, the stability of SE2L can be increased. However, longer response time requires longer safety distance. User must perform risk assessment before configuring the response time. Addition of maximum 1 cycle (30ms) has to be taken into account for the area switching.

Table-1. Response time of SE2L

		Response time (ms)							
OFF (ON->OFF)	60	90	120	150	180	210	240	270	
	300	330	360	390	420	450	480	510	
	540	570	600	630	660	690	720	750	
	780	810	840	870	900	930	960	990	
	1020	1050	1080	1110	1140	1170	1200	1230	
	1260	1290	1320	1350	1380	1410	1440	1470	
	1500	1530	1560	1590	1620	1650	1680	1710	
	1740	1770	1800	1830	1860	1890	1920	1950	
	1980	2010							
	ON (OFF->ON)								270
300		330	360	390	420	450	480	510	
540		570	600	630	660	690	720	750	
780		810	840	870	900	930	960	990	
1020		1050	1080	1110	1140	1170	1200	1230	
1260		1290	1320	1350	1380	1410	1440	1470	
1500		1530	1560	1590	1620	1650	1680	1710	
1740		1770	1800	1830	1860	1890	1920	1950	
1980		2010							

## (9) Area Switching

A maximum of 32 sets of area (128 area sets when encoder input function is used) can be configured in SE2L. However the maximum configurable area number differs depending on the selected function such as, muting and dual protection. Table 2 shows the maximum configurable area number according to the used mode. External input signals are provided in SE2L for switching the area. Each signal has a pair of normal and inverted signal. For example it is necessary to provide both input signal IN\_A and inverse IN\_A signal to switch the area. Error will occur if IN\_A and inverse IN\_A signals do not complement each other. Table 3-2 below shows the combination of input signal to switch the area. Area in use will be displayed in the 7 segment LED of SE2L. It is also possible to configure area input delay. Configure the necessary delay required for the system to provide stable input signals to SE2L. The default value is 30ms.

There are maximum 5 input pairs (a pair is a combination of normal and inverted signal) in SE2L therefore, it can operate with maximum 32 sets of area. Further, it is also possible to switch the area through the speed monitoring of increment encoder signal connected to SE2L.

Table-2. Input combination for area switching

Mode	Protection	Max. internal input	Max. Area	Max. encoder area
Standard	1	5	32	-
	2	5	32	-
EDM	1	4	16	-
	2	4	16	-
MUTING / EDM	1	2	4	-
	2	1	2	-
Encoder *1	1	3	7	128 *2
	2	3	7	128 *2

\*1 Muting function mode cannot be used if encoder input mode is selected.

\*2 Among the 8 input patterns at least one pattern must be used for encoder input.

Other 7 remaining patterns can be selected to be used as static input or not in use. A pattern with encoder input mode can have maximum 128 sets of area.

Table-3. Input combination for area switching

Area	IN_A	IN_B	IN_C	IN_D	IN_E	IN_A	IN_B	IN_C	IN_D	IN_E
1	ON	ON	ON	ON	ON	OFF	OFF	OFF	OFF	OFF
2	OFF	ON	ON	ON	ON	ON	OFF	OFF	OFF	OFF
3	ON	OFF	ON	ON	ON	OFF	ON	OFF	OFF	OFF
4	OFF	OFF	ON	ON	ON	ON	ON	OFF	OFF	OFF
5	ON	ON	OFF	ON	ON	OFF	OFF	ON	OFF	OFF
6	OFF	ON	OFF	ON	ON	ON	OFF	ON	OFF	OFF
7	ON	OFF	OFF	ON	ON	OFF	ON	ON	OFF	OFF
8	OFF	OFF	OFF	ON	ON	ON	ON	ON	OFF	OFF
9	ON	ON	ON	OFF	ON	OFF	OFF	OFF	ON	OFF
10	OFF	ON	ON	OFF	ON	ON	OFF	OFF	ON	OFF
11	ON	OFF	ON	OFF	ON	OFF	ON	OFF	ON	OFF
12	OFF	OFF	ON	OFF	ON	ON	ON	OFF	ON	OFF
13	ON	ON	OFF	OFF	ON	OFF	OFF	ON	ON	OFF
14	OFF	ON	OFF	OFF	ON	ON	OFF	ON	ON	OFF
15	ON	OFF	OFF	OFF	ON	OFF	ON	ON	ON	OFF
16	OFF	OFF	OFF	OFF	ON	ON	ON	ON	ON	OFF
17	ON	ON	ON	ON	OFF	OFF	OFF	OFF	OFF	ON
18	OFF	ON	ON	ON	OFF	ON	OFF	OFF	OFF	ON
19	ON	OFF	ON	ON	OFF	OFF	ON	OFF	OFF	ON
20	OFF	OFF	ON	ON	OFF	ON	ON	OFF	OFF	ON
21	ON	ON	OFF	ON	OFF	OFF	OFF	ON	OFF	ON
22	OFF	ON	OFF	ON	OFF	ON	OFF	ON	OFF	ON
23	ON	OFF	OFF	ON	OFF	OFF	ON	ON	OFF	ON
24	OFF	OFF	OFF	ON	OFF	ON	ON	ON	OFF	ON
25	ON	ON	ON	OFF	OFF	OFF	OFF	OFF	ON	ON
26	OFF	ON	ON	OFF	OFF	ON	OFF	OFF	ON	ON
27	ON	OFF	ON	OFF	OFF	ON	OFF	ON	ON	ON
28	OFF	OFF	ON	OFF	OFF	ON	ON	OFF	ON	ON
29	ON	ON	OFF	OFF	OFF	OFF	OFF	ON	ON	ON
30	OFF	ON	OFF	OFF	OFF	ON	OFF	ON	ON	ON
31	ON	OFF	OFF	OFF	OFF	OFF	ON	ON	ON	ON
32	OFF	OFF	OFF	OFF	OFF	ON	ON	ON	ON	ON

## (10) Increment encoder

In SE2L there are 2 pairs of encoder input terminals for connecting 2 units of dual channel incremental encoder signals. Area will be switched depending on the encoder speed. Direction of travel is detected by encoder's phase A and phase B signal that have the phase difference of 90°. Speed and rotating direction of both encoders are constantly monitored to detect abnormal travel and stop the AGV.

## (11) Ethernet communication

Measurement data of SE2L can be obtained from the Ethernet communication. For the communication specification of SE2L, contact the nearest distributor or sales representative. Water proof Ethernet connector is located at the back of SE2L. To connect sensor with PC use an Optional Ethernet cable (SE9Z-HS2-XCD13).

### • Ethernet Setting

#### a) Default setting

Factory default value is shown below.  
IP address: 192.168.0.10  
Default gateway: 192.168.0.254  
Subnet mask: 255.255.255.0  
Port number: 10940

#### b) Changing the IP address

IP address can be changed by using SLS project Designer. Refer to section 7.13 and 7.9.1 for details, refer to the user's manual.

## (12) Function to configure SE2L by SD card

Configuration generated by SLS Project Designer can be saved in a SD card. It is possible to transfer the setting directly from the SD Card to SE2L without connecting to a PC. The type of SD card should be Micro SD card when this function is used.

Create a project file with set the serial number and password of the SE2L and save it on the SD card using SLS Project Designer.

When the SD card is inserted to the specified SE2L, settings are automatically transferred. Setting will not be transferred to the unspecified SE2L.

## (13) Master-Slave Function

Maximum 4 units of SE2L can be interconnected using RS-485 for Master/slave operation. One unit will function as a master unit communicating with up to 3 units that function as slaves via safety communication channel. Use the SLS Project Designer to configure the devices.

Area switching of the slave unit is linked with the master unit while the slave units transmit the object detection information to the master which controls the OSSD. It is also possible to use each slave unit's OSSD. Figure 5 shows the connection example.

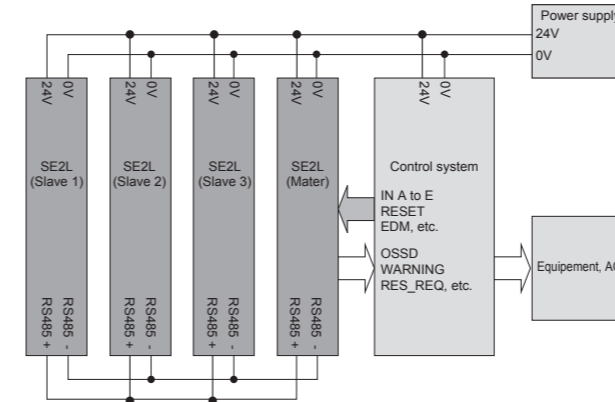

Fig-5. Connection example (When OSSD of slaves are not in use)

## 6 Light interference

SE2L uses pulsed laser for object detection. Light sources in the surrounding could interfere with its operation leading to false detection. User should examine the surroundings environments before installing the SE2L. Some of the light sources that could interfere with SE2L are as below.

- (1) Incandescent light
- (2) Fluorescent light
- (3) Stroboscopic light
- (4) Flashing beacon
- (5) Sunlight
- (6) Infrared light sources

In case the light source cannot be avoided during the operation, SE2L should be installed with the light source located at ±5 degrees or more from the detection plane to prevent the interference (Figure 6).

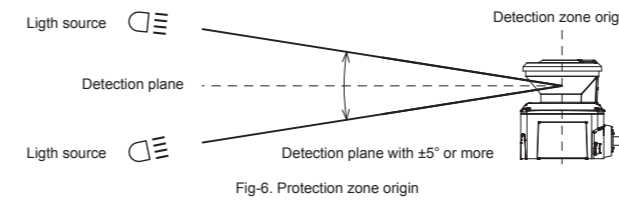

Fig-6. Protection zone origin

## 7 Mutual interference

Cautions are required while using two or more units of SE2L or identical products as pulsed laser signal from one another could lead to false detection. Figures below show the installation method for avoiding the mutual interference.

### (1) Changing the height of installation

Install at different heights to separate the mutual detection plane by 5 degrees or more.

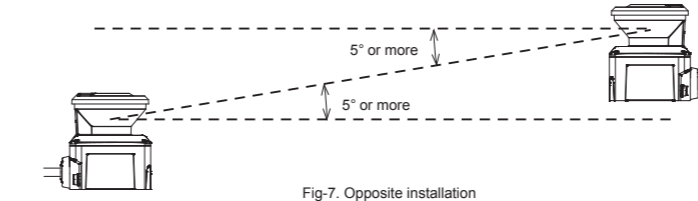

Fig-7. Opposite installation

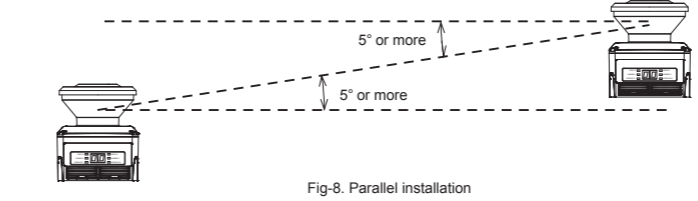

Fig-8. Parallel installation

### (2) Changing the angle of installation

Change the installation angle of SE2L by 5 degrees or more from the mutual detection plane.

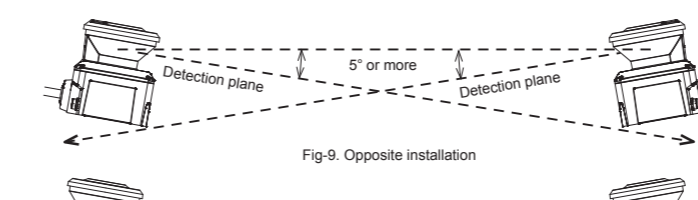

Fig-9. Opposite installation

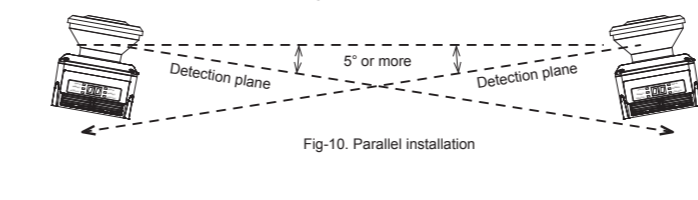

Fig-10. Parallel installation

## (3) Adding a shield between SE2Ls

Add a shield between SE2Ls such that laser beam of one unit cannot reach the other to avoid the possible mutual interference.

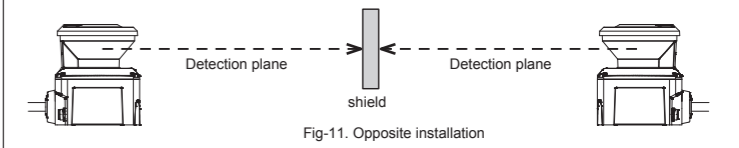

Fig-11. Opposite installation

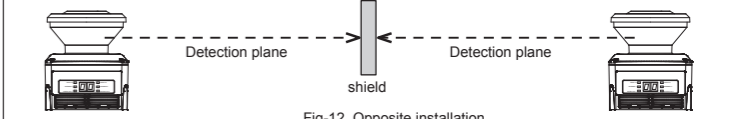

Fig-12. Opposite installation

## 8 High reflective background

Measured value will be longer than the actual distance of the object due to high reflective background leading to wrong detection. When high reflective background cannot be avoided in the working environment, additional distance of 200mm is necessary while configuring the protection and warning zones (Figure 13).

\* Specification of Distance tolerance is "+100mm".

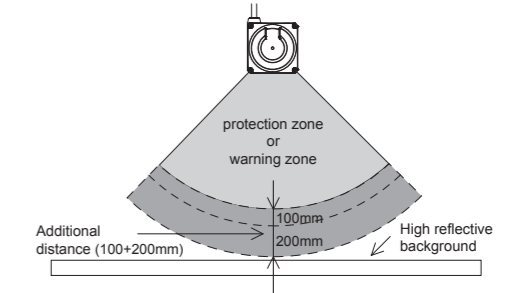

Fig-13. Additional distance under high reflective background

## 9 Limited detection capability zone

The limited detection capability zone is defined as a region between the optical window and start of the detection zone. The limited detection capability zone of the SE2L is 90mm from the origin of SE2L (Figure 14). Presence of object with low reflectance may not be detected in this zone.

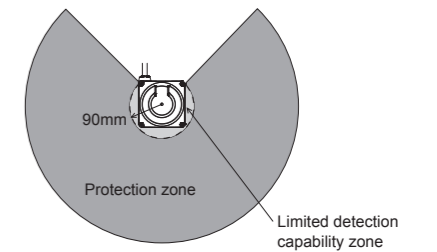

Fig-14. Limited detection capability zone



## 10 Wiring

Wiring example and cautions are shown below.

### (1) Precautions

- During electric wiring make sure that all devices are disconnected from power supply. Switch off all the power supply during wiring. Confirm that power supply is OFF.
- Do not exceed cable length stated in the specification of SE2L.

### (2) Power supply

Make sure that power supply is within the range of 24VDC±10%. For battery operation, power supply should be within the range of 24VDC -30% / +20%. SE2L could be damaged if rated output voltage exceeds this range.

### (3) Wiring example

Standard (With maximum 32 sets of area)

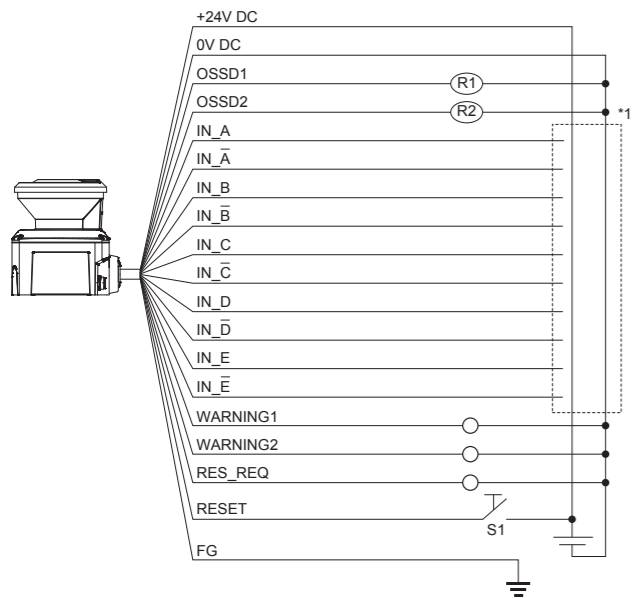

Fig-15. Wiring Example

R1 and R2: External equipment (Safety relay, Electromagnetic contactor)  
S1: Interlock reset switch  
\*1 Refer to section 5. (9) for the detail on area switching.

### (4) Wire color and function

Color	Signal	Function	Description	PinNo.	AWG
Brown	+24V DC	Power	Power Supply: 24V DC	1	22
Blue	0V DC	Power	Power Supply: 0V DC	2	22
Red	OSSD1	Output	Protection zone output 1	3	26
Yellow	OSSD2	Output	Protection zone output 2	4	26
Red / Black	OSSD3 / WARNING1	Output	Protection zone output 3 / Warning zone output 1	5	28
Yellow / Black	OSSD4 / WARNING2	Output	Protection zone output 4 / Warning zone output 2	6	28
Purple	IN_A	Input	Area Switching Input A	7	28
Gray	IN_B / MUTING3	Input	Area Switching Input B / Muting input 3	8	28
White	IN_C / OVERRIDE1 / ENC1_A	Input	Area Switching Input C / Override input 1 / Encoder input 1_A	9	28
Pink	IN_D / MUTING1 / ENC1_B	Input	Area Switching Input D / Muting input 1 / Encoder input 1_B	10	28
Green	IN_E / EDM1	Input	Area Switching Input E / External device monitoring 1	11	28
Purple / Black	IN_A	Input	Area Switching Input A invert	12	28
Gray / Black	IN_B / MUTING4	Input	Area Switching Input B invert / Muting input 4	13	28
White / Black	IN_C / OVERRIDE2 / ENC2_A	Input	Area Switching Input C invert / Override input 2 / Encoder input 2_A	14	28
Pink / Black	IN_D / MUTING2 / ENC2_B	Input	Area Switching Input D invert / Muting input 2 / Encoder input 2_B	15	28
Green / Black	IN_E / EDM2	Input	Area Switching Input E invert / External device monitoring 2	16	28
Yellow / Green	RESET1	Input	Reset input 1	17	28
Yellow / Blue	RESET2	Input	Reset input 2	18	28
Orange	RES_REQ1 / MUT_OUT1 / AUX_OUT1	Output	RES_REQ1: Request output 1 MUT_OUT1: Muting state output 1 AUX_OUT1: Synchronous signal / Error / Window contamination error / Window contamination warning.	19	28
Orange / Black	RES_REQ2 / MUT_OUT2 / AUX_OUT2	Output	RES_REQ2: Request output 2 MUT_OUT2: Muting state output 2 AUX_OUT2: Synchronous signal / Error / Window contamination error / Window contamination warning.	20	28
White / Blue (TP)	RS-485 +	Communication	Communication protocol RS-485	21	28
White / Red (TP)	RS-485 -	Communication	Communication protocol RS-485	22	28
Shield wire	FG	-	Frame ground	Case	-

## (5) Input/ Output circuit

- OSSD / Warning Output circuit  
OSSD / Warning outputs are N channel MOSFET type.

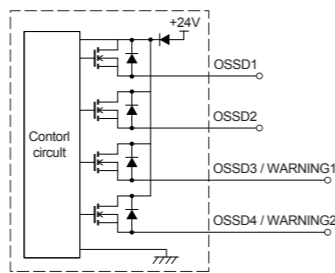

Fig-16. OSSD / Warning Output circuit

- Other output circuit  
RES\_REQ1, RES\_REQ2, MUT\_OUT1, MUT\_OUT2, AUX\_OUT1, AUX\_OUT2 outputs are PNP type.

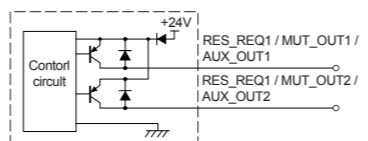

Fig-17. Output circuit

- Other output circuit  
Figure 18 shows input circuit for Area input, EDM1, EDM2, RESET1, RESET2, MUTING 1, MUTING 2, MUTING 3, MUTING4, OVERRIDE 1, and OVERRIDE 2 signals.

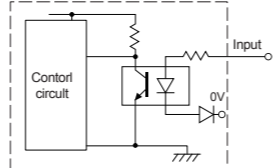

Fig-18. Input circuit

## 11 Troubleshooting

### (1) Troubleshooting

Situation	Possible reason	Solution suggestion
SE2L is not operating	Power supply is OFF/Over voltage Under voltage	Make sure power supply is ON. Check the supply voltage. Check the condition of the power supply cable.
	Cable is damaged	Replace with a new cable.
	Configuration is incomplete	Reconfigure SE2L.
	PC trouble	Check the PC's specification. Make sure the specification is compatible. Close the other unrelated applications and reconnect.
SE2L is not connected with the SLS Project Designer	Power supply is OFF	Make sure the power supply is ON. Check the supply voltage. Check the condition of the power supply cable.
	USB cable is not connected to USB port	Make sure the USB is connected to both PC and SE2L.
	Power supply is OFF	Make sure the power supply is ON. Check the supply voltage. Check the condition of the power supply cable.
Measurement data is not displayed	SE2L is in error/lockout state	Check the error number in the 7-segment table. Restart SE2L if it is blinking.
	Light interference	Mount SE2L at a location free from light interference. Refer to section 6 for light interference counter measures.
OSSD remain OFF even though the protection zone is free from obstacle	Mutual interference	Refer to section 7 for mutual interference counter measures.
	Contaminated optical window	Check for any contamination or damage on the optical window.
	Floor is detected	Make sure floor is not detected. Reconfigure the detection area.
	Background is detected	Make sure that the background is not inside the detection area. Reconfigure the detection area.
	Lockout state due to self-diagnostic function	Check the description of the error number and perform the possible solution as suggested.
	SE2L is interlocked	Check the configuration of the interlock function. If RESET is ON, supply SE2L with RESET signal.
	Mutual interference	Refer to section 7 for mutual interference counter measures.
	Light interference	Mount SE2L at a location free from light interference. Refer to section 6 for light interference counter measures.

### (2) Error number list

Table 4 shows the error number of the SE2L. These error numbers' information is displayed on the 7-segment display of the SE2L. If the SE2L is unable to resume normal operation, please contact the nearest distributor or sales representative for support.

Table-4. Error number list

Error No.	Details	Possible reason	Solution suggestion
45	Setting error/Incomplete setting	Reconfigure SE2L	Automatic recovery or Input reset. (During Interlock setting)
56	Invalid area error	Confirm the input status during area switching.	Automatic recovery or Input reset. (During Interlock setting)
57	Area Input Connection Error	Confirm the input status during area switching.	Automatic recovery or Input reset. (During Interlock setting)

Error No.	Details	Possible reason	Solution suggestion
59	Area sequence error	Confirm area switching sequence.	Automatic recovery or Input reset. (During Interlock setting)
58 5F	Encoder speed error	Make sure the encoder speed is correctly configured.	Automatic recovery or Input reset. (During Interlock setting)
5C	Encoder error	Confirm the encoder input status.	Automatic recovery or Input reset. (During Interlock setting)
5D	Encoder speed error	Confirm the input status during area switching.	Restart the power supply.
5E	Invalid area error (During Encoder is valid)	Confirm the input status during area switching.	Automatic recovery or Input reset. (During Interlock setting)
60 to 63	Motor error	Mount the sensor in a way that the vibration, bump stated in the specification does not exceed.	Automatic recovery or Input reset. (During Interlock setting)
64	Master / Slave communication error	Confirm the connection between master and slave.	Automatic recovery or Input reset. (During Interlock setting)
67 to 69	Laser error	Check the surrounding disturbance of the operating environment. And mount SE2L at a location free from mutual interference. Refer to section 5.2 mutual interference for counter measures.	Restart the power supply. (Replace SE2L if it does not recover even after restoring the power supply)
70	Optical interference / High reflective background	Mount SE2L at a location free from light interference. Refer to section 6. for light interference counter measures.	Automatic recovery or Input reset. (During Interlock setting)
72	Operating temperature error	Make sure that operating temperature is within specification.	Restart the power supply.
74 to 79	Power supply error	Make sure that voltage is within the specification	Restart the power supply.
7C	OSSD excess current error	Make sure the OSSD load is within the specification	Restart the power supply.
7D	Slave unit 1 error	Check the error code on slave unit 1	Automatic recovery or Input reset. (During Interlock setting)
7E	Slave unit 2 error	Check the error code on slave unit 2	Automatic recovery or Input reset. (During Interlock setting)
7F	Slave unit 3 error	Check the error code on slave unit 3	Automatic recovery or Input reset. (During Interlock setting)
80	Master unit error	Check the error code on master unit	Automatic recovery or Input reset. (During Interlock setting)
84 85 B1 to C0	Object in limited detection zone or contamination on the optical window	Clean the optical window (refer to chapter 8.5 of the manual). Further, remove any objects present inside the zone with limited detection capability (refer to chapter 5.4) of SE2L	Automatic recovery or Input reset. (During Interlock setting)
86	Mutual interference error	Mount SE2L at a location free from mutual interference. Refer to section 7 mutual interference for counter measures	Automatic recovery or Input reset. (During Interlock setting)
8F	SD card detection error	Check SD card file or check the specification of the SD card	Restart the power supply.
95 to 9A A8, AC	OSSD diagnostic error	Check the OSSD output wire	Restart the power supply.
A6	EDM1 input connection error	Check the EDM1 input wire	Restart the power supply.
A7	EDM2 input connection error	Check the EDM2 input wire	Restart the power supply.
A9	Reset input error	Check the RESET input wire	Restart the power supply.
AA	Reference monitor error	Check for the displacement of reference structure or SE2L position	Automatic recovery or Input reset. (During Interlock setting)
C1	Optical window is removed or contaminated	Replace or clean the optical window	Restart the power supply.
CE	Adjustment of the optical window is incomplete after replacement	Adjust the optical window	Automatic recovery or Input reset. (During Interlock setting)
CF	SE2L is not configured	Configure SE2L	Automatic recovery or Input reset. (During Interlock setting)
D3 to E6	Configuration is incomplete	Reconfigure SE2L	Restart the power supply.
F0	SD card initialization error	Remove the card and try again	Automatic recovery or Input reset. (During Interlock setting)
F1	SD card file content error	Check the setting file in the SD card	Automatic recovery or Input reset. (During Interlock setting)
Error other than (40 to F5)	Device Error	<ul style="list-style-type: none"> <li>Make sure that FG wire is correctly to the ground. Also check the surrounding disturbance of the operating environment.</li> <li>Mount the sensor within the stated vibration, bump in the specification.</li> <li>Replace SE2L if it does not recover even after restoring the power supply. Contact the nearest distributor or sales representative for the repair.</li> </ul>	Restart the power supply.

\* In 7 segment display B and D will display as b and d.

## 12 Instructions for using SE2L for the first time after purchase

SE2L does not operate without initial configuration. Install and use SLS Project Designer from CD provided with the product to configure SE2L.

### (1) SLS USB driver installation

- Connect the SE2L to PC's USB port. PC will detect the new hardware and open the "Found New Hardware Wizard".
- Select "Install from a list or specific location (Advanced)", insert the CD then click [Next-].
- Select "Search for the best driver in these locations". Then select "Include this location in the search", and click [Browse].
- Select the "Driver" folder, then click [OK].
- Click [Next-]. The wizard starts searching for the driver and dialogue box is shown.
- Windows starts installing the SLS USB driver.
- After clicking [Finish], the dialogue appears indicating new hardware is successfully installed.

To confirm that the SLS USB driver was successfully installed, go to the computer's device manager and expand the "Ports (COM and LPT)" list, "SLS USB Device Driver" should be seen as one of the COM ports.

### (2) SLS Project Designer installation

- Insert the CD into the CD-ROM drive.
- Click "SLS Project Designer\_\*\_\*.installer.exe".
- Follow the instructions of the installer and complete the installation.

### (3) Configuration Procedure

- Run the installed SLS Configurator software.
- Following application window will appear. Select [Create new configuration] and click [OK] button.

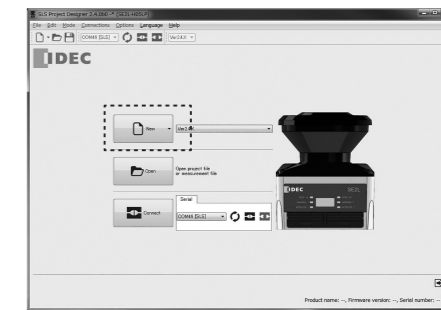

- Following configuration window will appear. Click [Connections] → [Connect] from the menu.



- Following password dialog box will appear. Enter default password [12345678] and click [OK].



- Following configuration window will appear. A message box [Device configuration is incomplete! Please reconfigure the device] will appear, refer to Chapter 7 of the user's manual and complete the function configuration, and write into the SE2L.

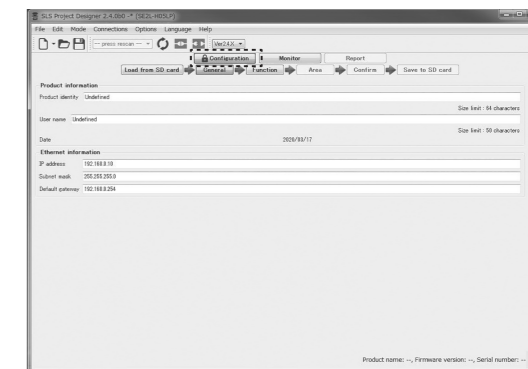

Configuration is completed.

**IDEC CORPORATION**

<http://www.idec.com>

Manufacturer : IDEC CORPORATION, 2-6-64 Nishimiyahara, Yodogawa-Ku, Osaka 532-0004, Japan  
EU Authorized Representative : APEM SAS  
55, Avenue Edouard Herriot BP1, 82303 Caussade Cedex, France