

Marking type (◎) : Marking type (B) . Non-marking type (Blank)
Rated Operating voltage (◇) : 100/110V AC (1)
115/120V AC (12)
200/220V AC (2)
230/240V AC (24)
Illumination Color (*) : Red (R) . Green (G) . Blue (S) . , Yellow (Y)
Amber (A) . Pure White (PW)

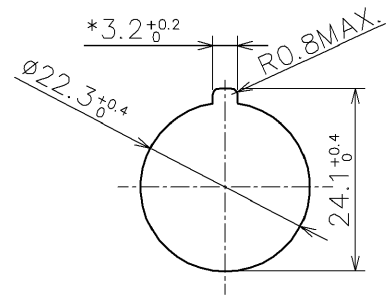

PANEL CUT-OUT

*THE 3.2^{+0.2} RECESS IS NOT NECESSARY WHEN NEITHER NAMEPLATE NOR ANTI-ROTATION RING IS USED.

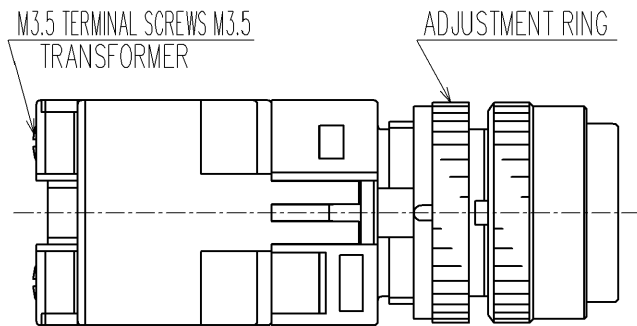
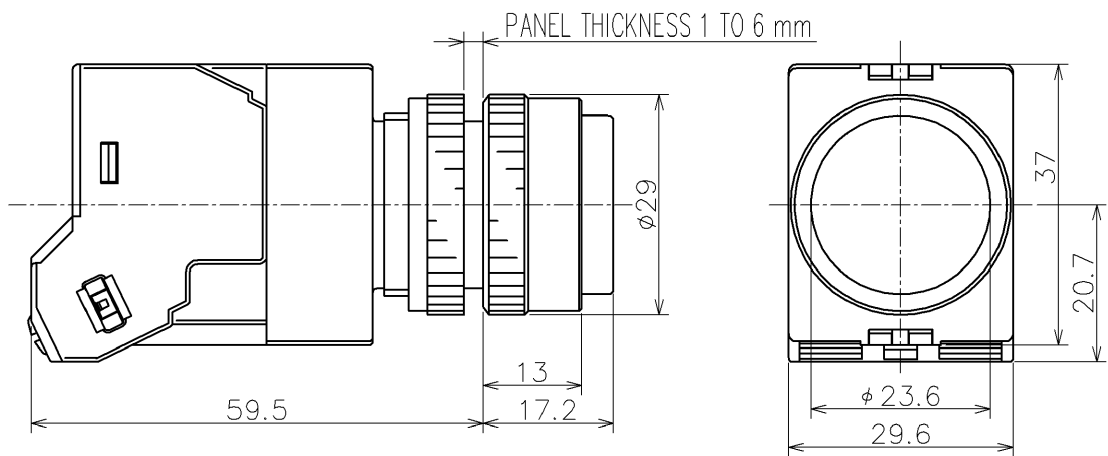

			Product Name: TW SERIES PILOT LIGHT
			Type Number: APW1◎◇6D*
Approved by	M.FUJIMOTO	2023/8/25	Dim.: mm
Checked by	Y.HANAOKA	2023/8/25	
Drawn by	R.GUO	2023/8/25	Drawing No. MA4-A05311B